

get started

INSTANT POT® RIO™
USER MANUAL

DUPC601BK

Instant Pot®

Welcome

to your new Instant Pot® RIO™!

This Instant Pot multi-cooker can help you cook healthy, delicious meals more easily and in less time. We hope you fall in love with Instant Pot cooking and enjoy it in your kitchen for years to come!

Scan For

More Information!



CONTENTS

Important safeguards	2
What's in the box	7
Using your Instant Pot RIO	9
Initial setup	14
Pressure cooking	18
Sautéing	25
Slow cooking	27
Yogurt making	28
Keep warm	30
Cleaning	31
Troubleshooting	33
Replacement parts	36
Learn more	37
Warranty	38
Notes	40

IMPORTANT SAFEGUARDS

⚠ WARNING

Failure to adhere to safety instructions may result in personal injury and/or property damage and may void your warranty.

READ ALL INSTRUCTIONS

Before using your Instant Pot RIO, please read all instructions, including the Safety Information below. Keep this manual for reference.

Placement

- **DO** place the appliance on a countertop only. Always operate the appliance on a stable, non-combustible, level surface.
- **DO** make sure all parts are dry and free of food debris before placing the cooking pot on the cooker base.
- **DO NOT** place the appliance on or close to a gas or electric burner, or an oven.
- **DO NOT** use the appliance near water or flame.
- **DO NOT** use outdoors. Keep out of direct sunlight.
- **DO NOT** place on anything that may block the vents on the bottom of the appliance.

General Use

The removable inner cooking pot is extremely hot during use and can be extremely heavy when full of ingredients.

- **DO** use oven mitts when handling the inner cooking pot and removing accessories.
- **DO** place hot accessories on a heat-resistant surface or cooking plate.
- **DO** use care when lifting the inner cooking pot from the cooker base to avoid burn injury and/or property damage.
- **DO** use extreme caution when the inner cooking pot contains hot food, hot oil or other hot liquids.

⚠ WARNING

Failure to adhere to safety instructions may result in personal injury and/or property damage and may void your warranty.

- **DO** use only the Instant Pot lid that came with this cooker base. Using any other pressure cooker lids may cause personal injury and/or property damage.
- **DO NOT** use the appliance without the removable inner cooking pot installed.
- **DO NOT** touch the metal portion of the lid, the appliance's hot surfaces, or any accessories during or immediately after cooking because they will be hot. Only use the side handles for carrying or moving.
- **DO NOT** use this appliance for deep frying or pressure frying with oil.
- **DO NOT** move the appliance while it is in use and use extreme caution when disposing of hot grease.
- **DO NOT** allow children or persons with reduced physical, sensory or mental capabilities to operate this appliance. Close supervision is necessary when any appliance is used by or near children and persons with reduced physical, sensory or mental capabilities. Children should not play with this appliance.
- **DO NOT** use the appliance for anything other than household use. It is not intended for commercial use.
- **DO NOT** leave the appliance unattended while in use.

Pressure Cooking

This appliance cooks under pressure. Allow the appliance to depressurize naturally or release all excess pressure before opening. Inappropriate use may result in burns, personal injury and/or property damage.

- **DO** make sure the appliance is properly closed before operating.
- **DO** check that the steam release valve is installed.
- **DO** use the pressure cooking lid when pressure cooking.
- **DO** turn the appliance off if steam escapes from the steam release valve and/or float valve in a steady stream for longer than 3 minutes. If steam escapes from the sides of the lid, turn the appliance off and make sure the sealing ring is properly installed.
- **DO** check the steam release valve, steam release pipe, anti-block shield and float valve for clogging before use.
- **DO NOT** remove the pressure cooking lid with unprotected hands.

⚠ WARNING

Failure to adhere to safety instructions may result in personal injury and/or property damage and may void your warranty.

- **DO NOT** attempt to force the lid off the Instant Pot cooker base.
- **DO NOT** move the appliance when it is under pressure.
- **DO NOT** cover or obstruct the steam release valve and/or float valve with cloth or other objects.
- **DO NOT** attempt to open the appliance until it has depressurized, and all internal pressure has been released. Attempting to open the appliance while it is still pressurized may lead to sudden release of hot contents and may cause burns or other personal injuries and/or property damage.
- **DO NOT** place your face, hands or exposed skin over the steam release valve or float valve when the appliance is in operation or has residual pressure, and do not lean over the appliance when removing the lid.

Overfill During Pressure Cooking

Overfilling may cause a risk of clogging the steam release pipe and developing excess pressure.

- **DO NOT** fill the inner cooking pot over the line labeled 'PC MAX – 2/3'.
- **DO NOT** fill the inner cooking pot over the line labeled '– 1/2' when cooking foods that expand during cooking such as rice, dried beans or dried vegetables.
- **DO** be aware that certain foods, such as applesauce, cranberries, pearl barley, oatmeal or other cereals, split peas, noodles, macaroni, rhubarb, or spaghetti can foam, froth, and sputter, and clog the pressure release device (steam vent). **DO NOT** fill the inner cooking pot higher than the '– 1/2' line when cooking these foods.
- **DO NOT** place oversized foods into the inner cooking pot as they may cause risk of fire, personal injury and/or property damage.
- **DO** check that sealing ring is properly installed.

Accessories

- **DO** use only accessories or attachments authorized by Instant Brands. The use of parts, accessories or attachments not recommended by the manufacturer may cause a risk of personal injury, property damage, fire or electric shock.

⚠ WARNING

- **DO** use only an authorized stainless-steel Instant Pot inner cooking pot to reduce the risk of pressure leakage.
- **DO** only replace the sealing ring with an authorized Instant Pot sealing ring to prevent personal injury, property damage and/or damage to the appliance.
- **DO NOT** use the included accessories in a microwave, toaster oven, convection or conventional oven, or on a ceramic cooktop, electric coil, gas range or outdoor grill.

Care and Storage

- **DO** let the appliance cool to room temperature before cleaning or storage.
- **DO NOT** store any materials in the cooker base when not in use.
- **DO NOT** place any combustible materials in the cooker base, such as paper, cardboard, plastic, Styrofoam or wood.

Power Cord

A short power-supply cord is used to reduce the risk resulting from it being grabbed by children, becoming entangled in, or tripping over a longer cord.

WARNING: Spilled food can cause serious burns. Keep appliance and cord away from children.

- Never drape cord over edge of counter, never use outlet below counter, and **NEVER** use with an extension cord.
- **DO NOT** let the power cord touch hot surfaces or open flame, including the stovetop.
- **DO NOT** use with power converters or adapters, timer switches or separate remote-control systems.

This appliance has a 3-prong grounding plug. To reduce the risk of electric shock:

- **ONLY** plug the power cord into a grounded electrical outlet.
- **DO NOT** remove ground.

If the unit includes a detachable power cord:

To connect, always attach the power cord to the appliance first, then plug the power cord into the wall outlet.

⚠ WARNING

Electrical Warning

The cooker base contains electrical components that are an electrical shock hazard. **Failure to follow these instructions may result in electric shock.**

To protect against electrical shock:

- To disconnect, select **Cancel**, then remove plug from power source. Always unplug when not in use, as well as before adding or removing parts or accessories, and before cleaning. To unplug, grasp the plug and pull from the outlet. **NEVER** pull from the power cord.
- **DO** regularly inspect the appliance and power cord.
- **DO NOT** operate the appliance if the power cord or plug is damaged, or after the appliance malfunctions or is dropped or damaged in any manner. For assistance, contact Customer Care by email at **info@instanthome.in**.
- **DO NOT** attempt to repair, replace or modify components of the appliance, as this may cause electric shock, fire, personal injury and/or property damage and will void the warranty.
- **DO NOT** tamper with any of the safety mechanisms, as this may result in personal injury and/or property damage.
- **DO NOT** put liquid or food of any kind into cooker base without the inner cooking pot.
- **DO NOT** immerse power cord, plug or the appliance in water or other liquid.
- **DO NOT** use the appliance in electrical systems other than 220 - 240 V ~ 50/60 Hz for SEA.
- **DO NOT** clean the appliance by rinsing it under a faucet.

SAVE THESE INSTRUCTIONS

⚠ WARNING

Failure to adhere to safety instructions may result in personal injury and/or property damage and may void your warranty.

WHAT'S IN THE BOX

Lid

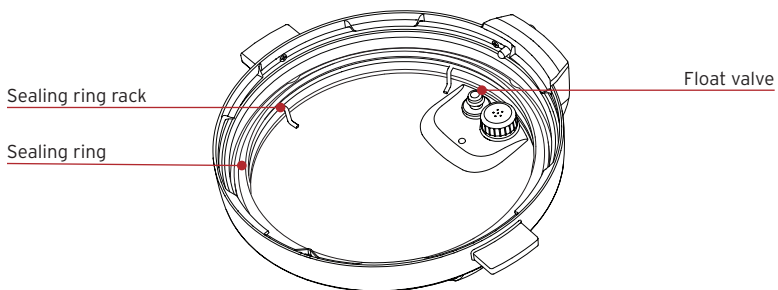
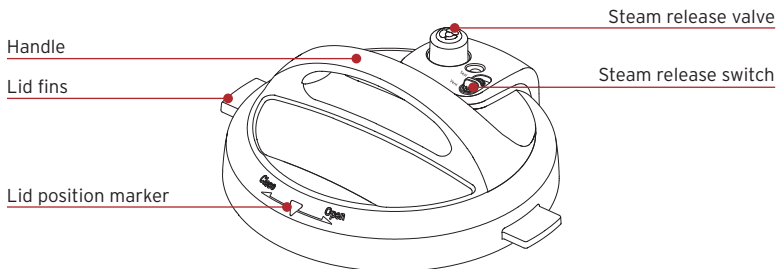

Stainless Steel Inner Cooking Pot

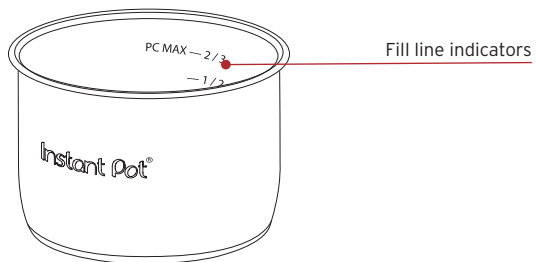

Cooker Base

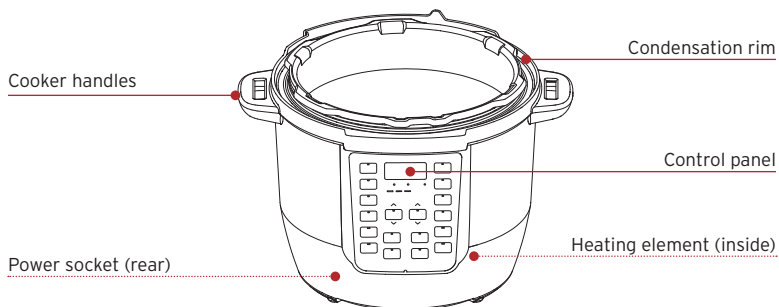

Parts + accessories

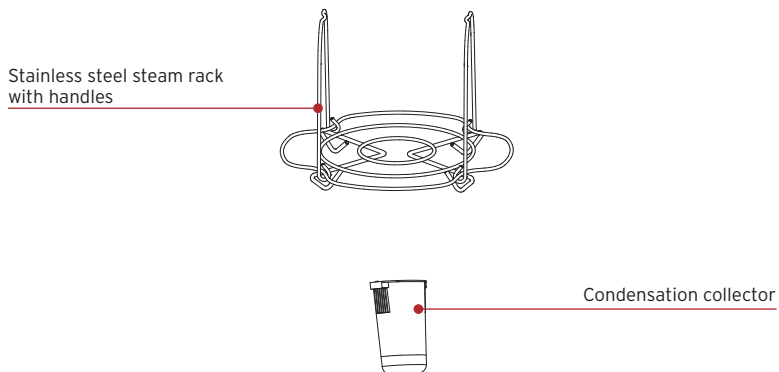

Illustrations are for reference only and may differ from the actual product.

Remember to recycle!

We designed this packaging with sustainability in mind. Please recycle everything that can be recycled where you live.

USING YOUR INSTANT POT RIO

Control panel

We've designed the RIO control panel to be simple to use and easy to read.

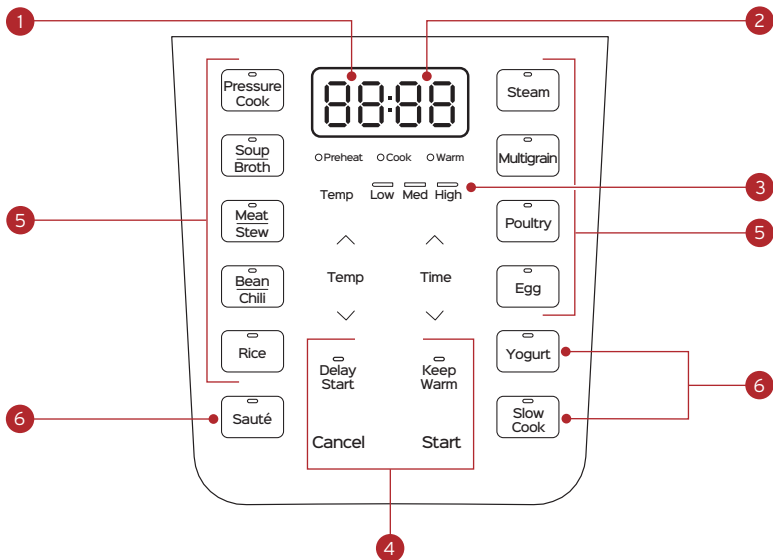

1. Time
 - Cooking time
 - Delay Start time
 - Keep Warm time
2. Status Messages
3. Time/temperature options
 - Pressure cooking: 1 pressure level
 - Non-Pressure cooking: 3 temperature levels
4. Smart Program Settings
 - Delay Start On/Off
 - Keep Warm On/Off
 - Cancel
 - Start
5. Pressure Cooking Smart Programs
 - Light shows the active Smart Program
6. Non-Pressure Cooking Smart Programs
 - Light shows the active Smart Program

Status messages

The control panel shows information you need to know when using your RIO.

OFF	Standby mode
On	Preheat mode
Lid	Lid not properly secured or missing
05:20	Time <ul style="list-style-type: none">• Smart Program: cooking time remaining• Delay Start: time until Smart Program starts• Keep Warm: time food has been warming
boil	Yogurt Smart Program is in pasteurizing cycle
Hot	Sauté Smart Program is ready to add food
End	Smart Program ended (Keep Warm is off)
Food burn	Overheating: see Troubleshooting
E*	Error: see Troubleshooting

Using the lid

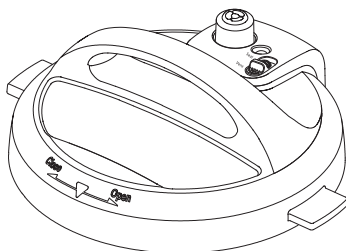

You'll use the pressure cooking lid for most cooking programs, and especially for pressure cooking. Always use the pressure cooking lid that came with this RIO cooker base.

Open the Lid

Turn the lid handle to align the ▼ on the lid with the ◻ at the side of the control panel.

Lift the lid up and off the cooker base.

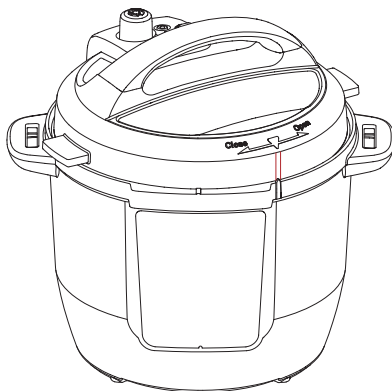

Close the Lid

1. Line up the ▼ on the lid with the ↑ at the side of the control panel.

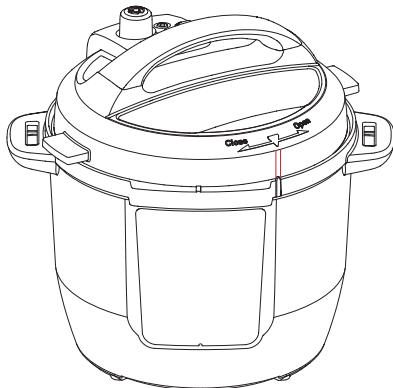

2. Turn the lid clockwise until the ▼ on the lid is centered over the control panel.

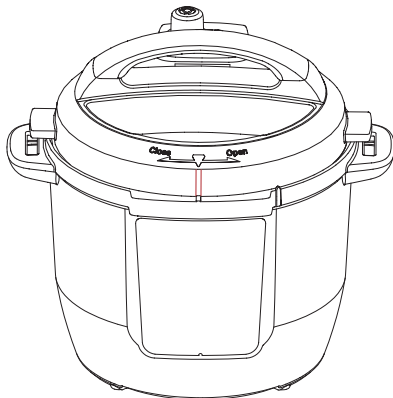

Turning the sound On/Off

Turn sound on

When in Standby mode, press and hold **Delay Start** and **Keep Warm** keys together until display shows **S On**.

Turn sound off

When in Standby mode, press and hold **Delay Start** and **Keep Warm** keys together until display shows **SOFF**.

Audible safety alerts (beeps) cannot be turned off.

Delay the start of cooking

You can set a Delay Start timer for a minimum of 10 minutes or a maximum of 24 hours.

3. Select a Smart Program, adjust the settings as you want, then press **Delay Start**.

*Once Delay Start has been selected, there is no way to return to the cooking settings. To adjust Smart Program settings, press **Cancel** and enter new selections.*

4. When the time field flashes, use the **Time** up/down arrows to adjust the delay time.
5. Delay Start begins automatically and the timer counts down.
6. When Delay Start ends, the Smart Program begins, and the display indicates **On**.

Delay Start is not available with the Sauté or Yogurt Smart Programs.

Reset Smart Programs to original settings

Reset Individual Smart Programs

With the cooker in Standby mode, press and hold one Smart Program button until the cooker returns to Standby and shows **OFF**.

The Smart Program's pressure level, cooking time and temperature are restored to the factory default setting.

Reset All Smart Programs

With the cooker in Standby mode, press and hold **Cancel** until the cooker beeps.

All Smart Program pressure levels, cooking times and temperatures are restored to the factory default setting.

INITIAL SETUP

Clean before use

1. Wash the inner cooking pot with hot water and soap. Rinse and use a soft cloth to dry the outside. Or you can wash the inner cooking pot in the dishwasher.
2. Wipe the heating element inside the cooker base with a soft cloth to ensure there are no stray packaging particles.

Setting up the condensation collector

The condensation collector sits at the back of the cooker base and accumulates overflow moisture from the condensation rim. It should be installed before cooking, then emptied and rinsed out after each use.

Install the condensation collector

- Align the grooves on the condensation collector with the tabs on the back of the cooker base and slide the condensation collector into place.

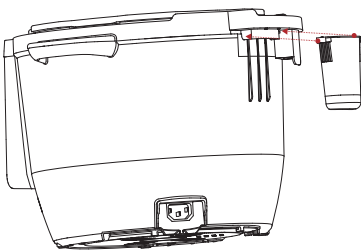

Remove the condensation collector

- Pull the condensation collector away from the cooker base; do not pull down.

Note the tabs on the cooker base and the grooves on the condensation collector.

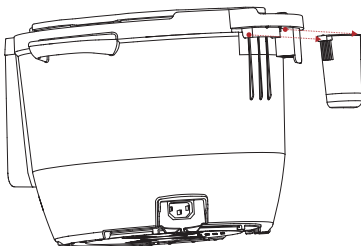

Using the Sealing Ring

When the pressure cooking lid is closed, the sealing ring installed on the underside of the lid creates an air-tight seal between the lid and the cooker base.

- The sealing ring must be installed before using the cooker and should be cleaned after each use.
- Sealing rings stretch over time with normal use. To keep your product safe, replace the sealing ring every 12 to 18 months. Replace sooner if you notice stretching, deformation, or damage.

⚠ WARNING

Failure to adhere to safety instructions may result in personal injury and/or property damage and may void your warranty.

Install the Sealing Ring

1. Place the sealing ring over the sealing ring rack and press it into place. Press down firmly to ensure there is no puckering.
2. The sealing ring should be snug and should not fall out when the lid is turned over.

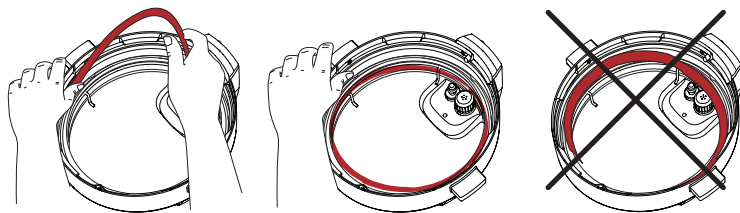

Remove the Sealing Ring

1. Grip the edge of the sealing ring and pull it out from behind the sealing ring rack.
2. Inspect the rack to ensure it is secured, centered, and an even height all the way around the lid. If the sealing ring rack is deformed, do not try to repair it.

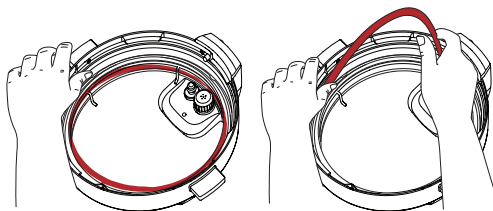

Plug in cord

- When you're ready to use your RIO, plug the electrical cord into the power socket on the back of the unit.

Test run

Setting up your new RIO for a test run is a great way to familiarize yourself with how the unit works before you actually cook a meal.

To perform a test run:

1. Follow the instructions for pressure cooking below.
2. Use 3 quarts water, but no food.
3. Set the cooking time to 5 minutes.
4. After the cooking session is done, discard any remaining water.
5. Wash and dry the inner cooking pot.

Now you're ready to cook a meal in your RIO!

PRESSURE COOKING

Pressure cooking uses pressurized steam to quickly and evenly cook foods.

How to pressure cook

Prep

Cut, chop, season or marinate your ingredients according to your recipe.

Preheat

1. Place the inner cooking pot into the cooker base.
2. Add ingredients to the inner cooking pot.
3. Place the lid on top of the inner cooking pot and be sure it is locked.
See 'How to close and lock the lid' below.
4. Choose a **Smart Program** for cooking and press its button on the control panel.
See 'Pressure cooking Smart Programs' below for full details.
5. If you want to increase or decrease the cooking time exactly, press **Time** up/down arrows.
6. **Keep Warm** setting is ON by default. Press **Keep Warm** again to turn it off.
7. Press **Start**. After 10 seconds, the display shows **On** and the RIO is building pressure.

It can take 10-15 minutes to reach the pressure setting for cooking. Frozen foods increase the preheating time.

Cook

1. When the pressure is ready, your RIO starts cooking .
2. The cooking timer starts counting down.
3. When the timer reaches 00:00, cooking stops.

You can press **Cancel** to stop a Smart Program at any time.

Release steam

Choose from the steam release method that works for your recipe.

See '**How to release steam**' below for full details.

Using liquid to create steam

Pressure cooking requires liquid in the inner cooking pot to produce the steam needed. Depending on the size of your RIO, here are the minimum amounts you'll need:

Instant Pot Size	Minimum Liquid for Pressure Cooking*
6 Quarts / 5.7 Litres	1 1/2 cups (12 oz / 375 mL)

**Unless otherwise specified in recipe.*

Pressure cooking liquids should be water-based, such as broth, stock, soup or juice. If using canned, condensed, or cream-based soup, add water as directed above.

How to close and lock the lid

For pressure cooking, the lid must be securely locked into place to prevent steam from escaping. When you place the lid on the cooker base. The RIO will not start pressurizing unless the lid is locked.

1. Line up the ▼ on the lid with the ⏏ at the side of the control panel.

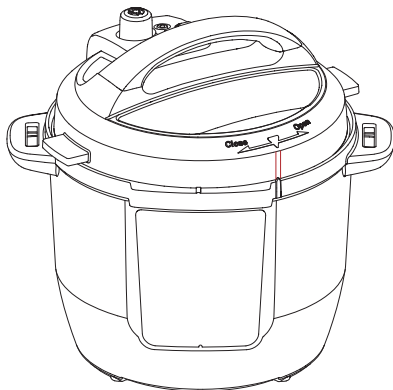

2. Turn the lid clockwise until the ▼ on the lid is centered over the control panel.

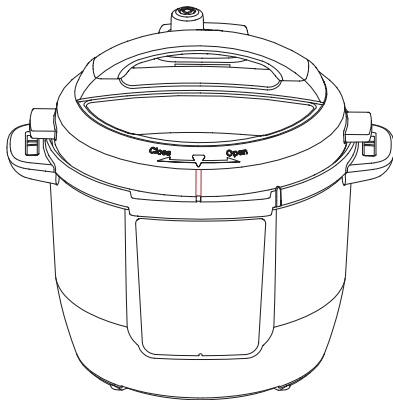

How to release steam

Instant Pot RIO can release steam in 2 different ways. Use the one that best fits the type of food you're cooking.

Natural steam release

Releases steam gradually over time (up to 40 minutes or more) as after cooking stops.

Use for: Foods that can simmer, like stews, chili, pasta, oatmeal, beans and grains.

1. After cooking, leave steam release switch in **Seal** position until all pressure is released.

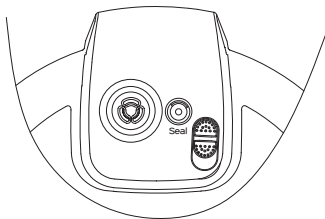

2. Float valve drops into lid when all steam is released.
3. After steam release, turn lid counterclockwise and remove the lid.

Quick steam release

Quickly releases steam after you press the steam release switch.

Use for: Foods that tend to overcook, like vegetables and seafood.

1. After cooking, set steam release switch to **Vent** position and wait for all pressure to release.

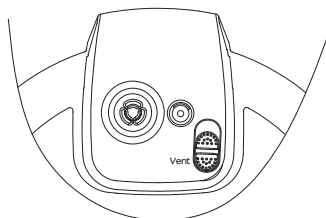

2. Float valve drops into lid when all steam is released.
3. After steam release, turn lid counterclockwise and remove the lid.

You can insert the handle into the cooking base vertically for easy storage.

⚠ CAUTION

This appliance uses pressure to cook. Allow the appliance to release all excess pressure and steam before opening the lid. Opening the lid before pressure is released may result in burns, personal injury and/or property damage. Read more in the Safety, Maintenance and Warranty sections.

Pressure Cooking Smart Programs

These Smart Programs are designed to pressure cook specific types of food. You can adjust the settings as your recipe directs.

Soup/Broth

Pressure	High		
Cooking Time	Default Cook Time	Min Cook Time	Max Cook Time
	30 minutes (00:30)	0 minute (00:00)	4 hours (04:00)

Tip

*The soup/broth remains clear due to a lack of boiling motion. Use **Natural Release** for soups with a higher starch content.*

Meat/Stew

Pressure	High		
Cooking Time	Default Cook Time	Min Cook Time	Max Cook Time
	35 minutes (00:35)	0 minute (00:00)	4 hours (04:00)

Tip

Allow meat to rest for 5-30 minutes after cooking to retain juices.

Bean/Chili

Pressure	High		
Cooking Time	Default Cook Time	Min Cook Time	Max Cook Time
	20 minutes (00:20)	0 minute (00:00)	4 hours (04:00)

Tips

*When cooking beans or legumes, always use **Natural Release** method. Make sure dry beans are completely submerged in water.*

Rice

Pressure	High		
Cooking Time	Default Cook Time	Min Cook Time	Max Cook Time
	12 minutes (00:12)	0 minute (00:00)	1 hour (01:00)

Tips

Use a 10-minute timed steam release for fluffy rice.

Steam

Pressure	High		
Cooking Time	Default Cook Time	Min Cook Time	Max Cook Time
	10 minutes (00:10)	0 minute (00:00)	4 hours (04:00)

Tips

Use the provided silicone steam rack to elevate food above cooking liquid. Use **Quick Release** method to avoid overcooking food.

Multigrain

Pressure	High		
Cooking Time	Default Cook Time	Min Cook Time	Max Cook Time
	40 minutes (00:40)	0 minute (00:00)	4 hours (04:00)

Poultry

Pressure	High		
Cooking Time	Default Cook Time	Min Cook Time	Max Cook Time
	10 minutes (00:10)	0 minute (00:00)	4 hours (04:00)

Tips

Allow meat to rest for 5-30 minutes depending on size. It will retain cooking juices for tender, succulent meat.

Egg

Pressure	High		
Cooking Time	Default Cook Time	Min Cook Time	Max Cook Time
	5 minutes (00:05)	0 minute (00:00)	60 minutes (1:00)

Tips

Adjust cooking time as recipe directs.

Use **Natural Release** method when cooking foods that expand.

SAUTÉING

Use Sauté in place of a frying or saucepan. Sautéing can deepen the flavors of your food, or can simmer, thicken or reduce sauces.

Choose from these settings in the Sauté Smart Program:

Cooking Temperature	Low/Medium/High (default is set to High)		
Cooking Time	Default Cook Time	Min Cook Time	Max Cook Time
	30 minutes (00:30)	1 minute (00:01)	1 hour (01:00)

How to sauté

Prep

Cut, chop, season or marinate your ingredients according to your recipe.

Preheat

1. Place the inner cooking pot into the cooker base.
2. Add ingredients to the inner cooking pot.
3. Press **Sauté** on the control panel.
4. The default temperature is highlighted. Press **Temp up/down** arrows to select **Low**, **Medium** or **High** temperature.
5. The default cooking time will flash on the display. Press **Time up/down** arrows to adjust cooking time.
6. Press **Start**. The display shows **On**.

Cook

1. When display shows **Hot**, add ingredients.
2. The display will begin counting down the time.
3. When timer ends, display shows **End**.
4. Press **Cancel** if you want to finish cooking before timer runs out.

Deglazing

Deglazing is the process of adding a liquid to a hot pan, releasing all of the delicious, caramelized pieces stuck to the bottom.

1. Remove food from inner cooking pot.
2. Add water, broth, or wine.
3. Use wooden spoon or silicone spatula to loosen food stuck to bottom of the inner cooking pot.

Sautéing before Pressure or Slow Cooking

Quite often, you'll want to sauté foods to brown them before further cooking them.

1. Sauté ingredients.
2. Press **Cancel**.

*You can deglaze the inner cooking pot now before switching to **Pressure Cook** or **Slow Cook** (see *Deglazing*).*

3. Select from the Smart Program.

SLOW COOKING

Slow Cook lets you make your favorite simmering and stewing recipes – just like grandma used to make. This program does not use pressure to cook food. Make sure steam release is set to **Venting** or use a glass lid with a venting hole.

Choose from these settings in the Slow Cook Program:

Cooking Temperature	Low/Medium/High (default is set to Medium)		
Cooking Time	Default Cook Time	Min Cook Time	Max Cook Time
	6 hours (06:00)	30 minutes (00:30)	24 hours (24:00)

How to slow cook

Prep

Cut, chop, season or marinate your ingredients according to your recipe.

Cook

1. Place the inner cooking pot into the cooker base.
2. Add ingredients to the inner cooking pot.
3. Place the lid on top of the cooking pot and be sure it is locked.
See 'How to close and lock the lid' above.
4. Press **Slow Cook** on the control panel.
5. The default temperature is highlighted. Press **Temp up/down** arrows to select **Low**, **Medium** or **High** temperature.
6. The default cooking time will flash on the display. Press **Time up/down** arrows to adjust cooking time.
7. Press **Start**. The display shows **On**.

Keep Warm

When cooking completes, the display shows **End** if **Keep Warm** is turned off. If not, the timer begins counting from **00:00** up to 10 hours (**10:00**).

YOGURT MAKING

You can use your RIO to easily make delicious, fermented dairy and non-dairy yogurt.

Process	Default Cook Time	Default Temperature	Custom Time Range
Pasteurize	3 minutes (00:03)	High	N/A
Ferment (dairy)	8 hours (08:00)	Low	N/A
Ferment (non-dairy, custom)	8 hours (08:00) (adjustable)	Low (adjustable)	Minimum 30 minutes (00:30) Maximum 99 hours, 30 minutes (99:30)

Note: Automatic Keep Warm and Delay Start are not available.

How to make yogurt

Pasteurizing Milk

1. Add milk to the inner cooking pot and place the inner cooking pot into the cooker base.
2. Place the lid on top of the cooker base and lock the lid.
3. Press **Yogurt** on the control panel. The default temperature is highlighted.
4. Press **Temp up/down** arrows to select **Low**, **Medium** or **High** temperature.
5. The default cooking time will flash on the display. Press **Time up/down** arrows to adjust cooking time.
6. The display shows **Hot** for 3 seconds and then shows **boIL**.
7. When pasteurization finishes, display shows **End**.

Note: Milk must reach a minimum of 161°F / 72°C for pasteurization to occur

*Note: If Temp level is set to **High**, no time display will be available. The cooking time shows **boiL**. If Temp is set to **Med or Low**, the cooking time shows the set time.*

Adding Culture/Starter

1. Allow pasteurized milk to cool to 43°C / 110°F.
2. Add a starter culture to the milk according to package instructions.
If using plain yogurt as a starter, ensure that it contains an active culture. Mix in 2 tbsp (30 mL) of yogurt per 1 gallon (3.7 L) of milk or follow a trusted recipe.
3. Place and close lid.

Ferment

1. Press **Yogurt**.
2. Cycle to Medium by pressing **Yogurt** again; display shows 8 hours (08:00).
3. Use **Time up/down** arrows to adjust the fermentation time if needed.
4. The display shows timer counting down from to set time to 00:00.
5. When fermentation completes, the cooker beeps and display shows **End**.
A longer fermentation period will produce tangier yogurt.
6. Allow yogurt to cool.
7. Place in fridge for 12-24 hours to develop flavors.

How much to make?

Instant Pot Size	Minimum Milk Volume	Maximum Milk Volume
6 Quarts / 5.7 Liters	4 Cups (32 oz / 1000 mL)	4 Quarts (128 oz / 3.8 L)

KEEP WARM

The Keep Warm setting turns on automatically after cooking on all Smart Programs except Sauté and Yogurt. You can also use Keep Warm to reheat food.

Keep warm after cooking

1. When automatic warming begins, the timer shows the time passed, up to 10 hours.
2. To turn automatic warming off (either during cooking or during automatic warming), press **Keep Warm** or **Cancel** and the light above the button turns off.

Reheat and keep warm

1. When in Standby mode, press **Keep Warm**.
2. Press Temp up/down arrows to select **Low**, **Medium** or **High** temperature level.
3. Press the **Time up/down** arrows to adjust the timer.

CLEANING

Clean your RIO after each use. Always unplug the unit and let all parts cool to room temperature before cleaning. Before use or storing, make sure all surfaces are dry.

Part	Cleaning instructions
Accessories <ul style="list-style-type: none">• Steam/Egg Rack• Condensation Collector	<ul style="list-style-type: none">• Wash after each use.• Hand wash with hot water and mild dish soap or wash in dishwasher, top rack.• Never use harsh chemical detergents, powders or scouring pads on accessories.• Empty and rinse condensation collector after each use.
Lid and Parts <ul style="list-style-type: none">• Anti-Block Shield• Sealing Ring• Steam Release Valve• Float Valve• Silicone Cap	<ul style="list-style-type: none">• Hand wash with hot water and mild dish soap or wash in dishwasher, top rack.• Remove all small parts from lid before washing.• With steam release valve and anti-block shield removed, clean interior of steam release pipe to prevent clogging.• To drain water from the lid after dishwashing, grasp the lid handle and hold the lid vertically over a sink, then turn it all the way around.• After cleaning, store the lid upside down on the cooker base.• Store sealing rings in a well-ventilated area to disperse odor.• To eliminate odors from sealing ring, add 1 cup (8 oz / 250 mL) water and 1 cup (8 oz / 250 mL) white vinegar to cooking pot, and run Pressure Cook for 5-10 minutes, then use Quick Steam Release.
Inner Cooking pot	<ul style="list-style-type: none">• Wash after each use.• Hand wash with hot water and mild dish soap or wash in dishwasher*.• Hard water stains may need a vinegar-dampened sponge and scrubbing to remove.• For tough or burned food residue, soak in hot water for a few hours before cleaning.• Dry all exterior surfaces before placing in cooker base.

Part	Cleaning instructions
Power cord	<ul style="list-style-type: none">• Use a barely-damp cloth to wipe any particles off cord. Always disconnect from power source before cleaning power cord.
Cooker base	<ul style="list-style-type: none">• Wipe the inside of the cooker base as well as the condensation rim with a barely-damp cloth, and allow to air dry.• Clean the outside of the cooker base and the control panel with a soft, barely-damp cloth or sponge.

**Some discoloration may occur after machine washing, but this will not affect the cooker's safety or performance.*

TROUBLESHOOTING

Problem	Cause	Solution
Difficulty closing lid	Sealing ring not properly installed.	Reposition sealing ring, ensure it is snug behind sealing ring rack.
	Contents in cooker are still hot.	Set Steam Release switch to Vent, then lower lid onto cooker base.
	Pressure inside the cooker.	Release pressure according to recipe; only open lid after float valve has dropped down.
Inner pot is stuck to lid when cooker	Cooling of inner pot may create suction, causing inner pot to adhere to the lid.	To release the vacuum, set Steam Release to Vent.
Steam leaks from side of lid	No sealing ring in lid.	Install sealing ring.
	Sealing ring damaged or not properly installed.	Replace sealing ring.
	Food debris attached to sealing ring.	Remove sealing ring and clean thoroughly.
	Lid not closed properly	Open, then close lid.
	Sealing ring rack is warped or off-center.	Remove sealing ring from lid, check sealing ring rack for bends or warps. Contact Consumer Care.
	Cooking pot rim may be misshapen.	Check for deformation and contact Consumer Care.
Minor steam leaking/hissing from steam release vent during cooking cycle	Cooker is regulating excess pressure.	This is normal; no action required.
Steam gushes from steam release vent when Steam Release switch is in Seal position	Pressure sensor control failure.	Contact Consumer Care.
	Internal Steam Release valve not seated properly	Move the Steam Release switch quickly to Vent then back to Seal to ensure the Steam Release valve is seated correctly.

Problem	Cause	Solution
Display remains blank after connecting the power cord	Bad power connection or no power.	Inspect power cord for damage. If damage is noticed, contact Consumer Care. Check outlet to ensure it is powered.
	Cooker's electrical fuse has blown.	Contact Consumer Care.
Occasional clicking or light cracking sound	The sound of power switching and expanding pressure board when changing temperatures.	This is normal; no action needed.
	Bottom of the cooking pot is wet.	Wipe exterior surfaces of cooking pot. Ensure heating element is dry before inserting cooking pot into multi-cooker base.
Error code appears on display and multi-cooker beeps continuously	There is an issue with the multi-cooker.	Read "Error Codes" for instructions.

ERROR CODES

If the control panel shows an error code from this list, there is an issue with the Instant Pot RIO. Here are the actions you should take to fix the problem.

Problem	Cause	Solution
C1 C2 C6	Faulty sensor.	Contact Consumer Care.
C7 or NoPr	Heat element has failed.	Contact Consumer Care.
	Not enough liquid.	Add thin, water-based liquid to the cooking pot: 1 1/2 cups (12 oz / 375 mL)
Lid	Lid is not in the correct position for the selected program.	Open and close the lid. Do not use a lid when using Sauté.
Food burn	High temperature detected at bottom of cooking pot; multi-cooker automatically reduces temperature to avoid overheating.	Starch deposits at the bottom of the cooking pot may have blocked heat dissipation. Turn the multi-cooker off, release pressure according to the recipe, and inspect the bottom of the cooking pot.
PrSE	Pressure has accumulated during a non-pressure cooking program.	Set Steam Release switch to Vent.

LEARN MORE

There's a whole world of Instant Instant Pot information and help just waiting for you. Here are some of the most helpful resources.

Register your product

Scan For
More Information!



Instant Brands Connect App with 1000+ recipes

iOS and Android app stores

Join the community



WARRANTY

One (1) Year Limited Warranty

This One (1) Year Limited Warranty applies to purchases made from authorized retailers of Instant Brands LLC (“Instant Brands”) by the original appliance owner and is not transferable. Proof of original purchase date and, if requested by Instant Brands, return of your appliance, is required to obtain service under this Limited Warranty. Provided the appliance was used in accordance with the use & care instructions, Instant Brands will, in its sole and exclusive discretion, either: (i) repair defects in materials or workmanship; or (ii) replace the appliance. In the event that your appliance is replaced, the Limited Warranty on the replacement appliance will expire twelve (12) months from the date of receipt. Failure to register your product will not reduce your warranty rights. The liability of Instant Brands, if any, for any allegedly defective appliance or part will not exceed the purchase price of a comparable replacement appliance.

What is not covered by this warranty?

- Products purchased, used, or operated outside of the SEA
- Products that have been modified or attempted to be modified.
- Damage resulting from accident, alteration, misuse, abuse, neglect, unreasonable use, use contrary to the operating instructions, normal wear and tear, commercial use, improper assembly, disassembly, failure to provide reasonable and necessary maintenance, fire, flood, acts of God, or repair by anyone unless directed by an Instant Brands representative.
- Use of unauthorized parts and accessories.
- Incidental and consequential damages.
- The cost of repair or replacement under these excluded circumstances.

EXCEPT AS EXPRESSLY PROVIDED HEREIN AND TO THE EXTENT PERMITTED BY APPLICABLE LAW, INSTANT BRANDS MAKES NO WARRANTIES, CONDITIONS OR REPRESENTATIONS, EXPRESS OR IMPLIED, BY STATUTE, USAGE, CUSTOM OF TRADE OR OTHERWISE WITH RESPECT TO THE APPLIANCES OR PARTS COVERED BY THIS WARRANTY, INCLUDING BUT NOT LIMITED TO, WARRANTIES, CONDITIONS, OR REPRESENTATIONS OF WORKMANSHIP, MERCHANTABILITY, MERCHANTABILITY, FITNESS FOR A PARTICULAR PURPOSE OR DURABILITY.

Some states or provinces do not allow for: (1) the exclusion of implied warranties of merchantability or fitness; (2) limitations on how long an implied warranty lasts; and/or (3) the exclusion or limitation of incidental or consequential damages; so these limitations may not apply to you. In these states and provinces, you have only the implied warranties that are expressly required to be provided in accordance with applicable law. The limitations of warranties, liability, and remedies apply to the maximum extent permitted by law. This limited warranty gives you specific legal rights, and you may also have other rights which vary from state to state or province to province.

Product Registration

Please visit your respective country's website to register your new Instant Brands appliance. Failure to register your product will not diminish your warranty rights. You will be asked to provide the store name, date of purchase, model number (found on the back of your appliance) and serial number (found on the bottom of your appliance) along with your name and email address. The registration will enable us to keep you up to date with product developments and recipes and contact you in the unlikely event of a product safety notification. By registering, you acknowledge that you have read and understand the instructions for use, and warnings set forth in the accompanying instructions.

Warranty Service

To obtain warranty service, please scan the below QR code for more information. You can also create a support ticket online at each country's website or contact the country's customer service via calling. If unable to resolve issue, you may be asked to send your appliance to the Service Department for quality inspection. Instant Brands is not responsible for shipping costs related to warranty service. When returning your appliance, please include your name, mailing address, email address, phone number, and proof of the original purchase date as well as a description of the problem you are encountering with the appliance.

Scan For
More Information!



NOTES

Instant Pot®

Download Free App



© 2023 Instant Brands LLC.